

Disassembly and Repair of Type IC Joints - 6000 Series

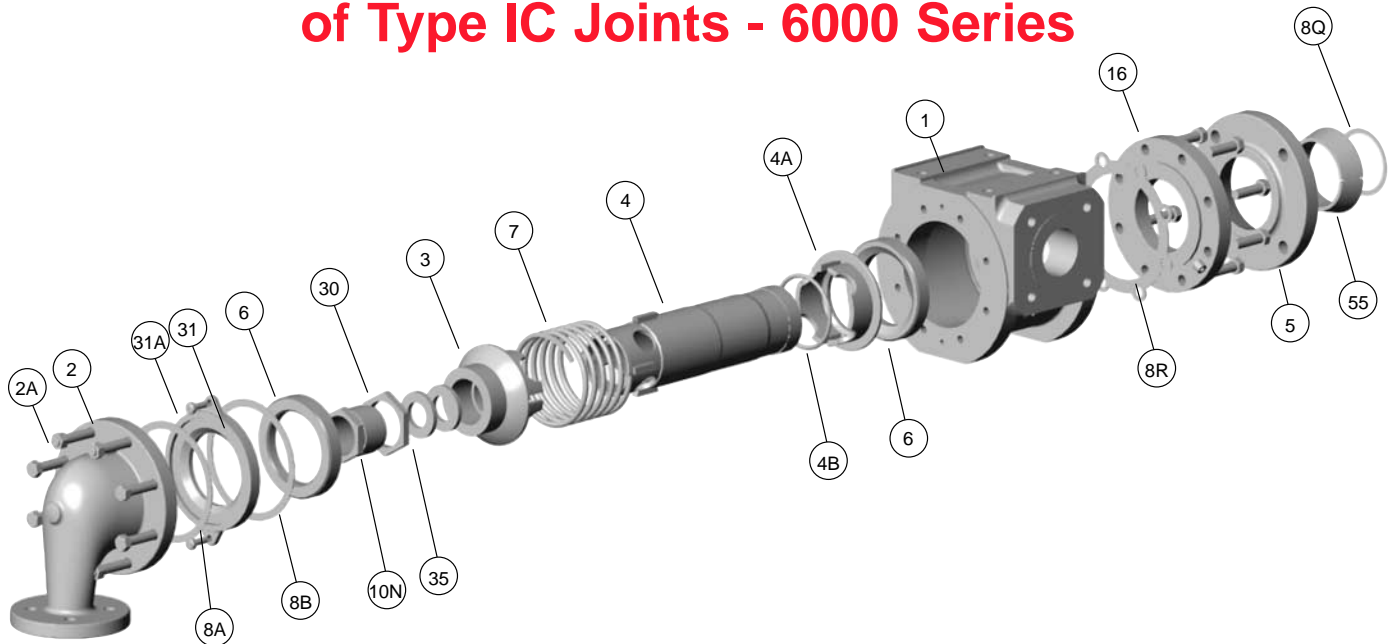

Type 6000NAW-IC

REPAIR KITS ARE AVAILABLE CONSISTING OF:

Item #	Qty	Description
4B	1	O-Ring
6	1	Carbon Seal
8	1	Gasket
8Q	1	Copper Gasket
8R	1	Gasket
35	1	Packing

NOTE: Please follow your company's safety procedures whenever working on Kadant Johnson Rotary Joints and read all of the instructions completely before proceeding.

Please refer to the assembly drawings supplied with your Kadant Johnson Rotary Joint for part identification. If you have any further questions, please contact your Representative or Kadant Johnson.

REMOVAL:

STEP 1.

Close the inlet and outlet valves and allow the joint to cool down.

STEP 2.

Disconnect the inlet piping from the joint. Be careful of any pressure still in the system as this may be dangerous.

STEP 3.

Remove outlet head bolts (2A) freeing head (2) from the body. Tie or secure it to any adjacent support so that the flexible metal hose is not strained or bent.

STEP 4.

Loosen locknut (30) and packing gland (10N).

STEP 5.

Remove the hex nuts from the studs at quick release nipple flange (5).

STEP 6.

Remove the four mounting bolts securing the Kadant Johnson joint to the support bracket.

STEP 7.

Slide the joint out away from the roll (being careful not to bend the horizontal pipe). Try to keep all weight off of the horizontal pipe. Discard copper gasket (8Q) located inside the journal flange.

STEP 8.

Remove 'Q' nipple flange (5) and its two split tapered wedges (55). Be sure to keep the split wedges for reinstallation.

The joint is now ready for disassembly.

DISASSEMBLY:

STEP 9.

Position the rotary joint assembly upright with nipple (4) extending down into a piece of pipe or through a hole in the table. In that position, the joint body housing (1) will be resting on the pipe or table.

In the next step you will be removing the two assembly plate screws (31A). The internal joint spring force is contained by assembly plate (31); be alert as it releases.

STEP 10.

Using a press, apply pressure on the packing gland (10N) while removing the two round head screws (31A). Remove the two screws and break loose the gasket (8B).

STEP 11.

Lift off assembly plate (31) exposing the internal parts. CAUTION is advised as there is an internal spring force present.

STEP 12.

Remove the first carbon seal (6), thrust collar (3), spring (7), nipple (4), nipple body (4A) and the second carbon seal ring (6). Also remove the packing (35) from the thrust collar.

STEP 13.

Replace o-ring (4B) located in nipple body (4A). First slide the nipple body (4A) off of nipple (4).

Remove and discard the old o-ring. Using steel wool and a solvent, clean the o-ring groove and o-ring sealing surface on the nipple tube.

STEP 14.

Inspect the wear plate (16), nipple body (4A), thrust collar (3) and assembly plate (31) for scratches, grooving and pitting. Replace if damaged or worn.

STEP 15.

Install a new o-ring, lubricate the nipple tube and reinstall nipple body (4A) and set aside. Do not machine any of the metal components as it may lower the joint's rated pressure and pose a danger.

STEP 16.

Clean all gasket surfaces. Replace wear plate gasket (8R) if necessary by removing the wear plate (16).

REASSEMBLY:**STEP 17.**

Place a new carbon seal ring (6) (concave side facing outward) into the body housing.

STEP 18.

Set nipple assembly (4) into the body housing followed by spring (7) and thrust collar (3).

STEP 19.

Place gasket (8B) on body opening.

STEP 20.

Place carbon seal (6) on top of thrust collar (3) followed by assembly plate (31).

STEP 21.

Using the press, recompress the spring (be sure the keyways in the thrust collar are aligned with the keys on the nipple) and attach assembly plate (31) to body (1) with the two round head screws and lockwashers.

REINSTALLATION:**STEP 22.**

Slide 'Q' nipple flange (5) over nipple (4) with its taper facing outward away from the joint body.

STEP 23.

Place the two split tapered wedges (55) in the groove around nipple (4) then slide 'Q' nipple flange (5) over them to hold in place.

STEP 24.

Place a new copper gasket (8Q) into the recess of the journal flange.

STEP 25.

Lift the joint up and slide it over the horizontal pipe until the nipple seats against copper gasket (8Q) and the 'Q' nipple flange (5) is aligned over the studs on the journal flange. Loosely bolt the joint housing to the support bracket at this time.

STEP 26.

Thread hex nuts onto the studs tightening evenly. The 'Q' nipple flange (5) will not seat flush against the journal flange. There will be 1/8" to 3/16" space between them and this space should be the same around the 360° circumference.

SETTING THE JOINT:**STEP 27.**

With the joint housing loosely secured to the support bracket pull or slide the housing out away from the machine until it stops, then push it back in 1/8" and tighten the mounting bolts. Total movement possible back and forth is only 3/8" to 1/2". Make sure the nipple (4) is centered in wear plate (16).

STEP 28.

Place new packing (35) into thrust collar (3) followed by packing gland (10N). The number of pieces is listed on the assembly drawing.

STEP 29.

Clean the gasket surface on head casting (2), install a new gasket (8A) and secure in place with the hex head cap screws. Kadant Johnson joints use Grade 5 bolts or higher.

CARBON SEAL WEAR:**STEP 30.**

Periodically measure the carbon seal wear. Carbon seal wear measuring tools are available from Kadant Johnson.

Dimensions are for reference only and subject to change. Certified drawings are available on request. Please refer to Kadant Johnson Drawing Number A37640 for torque specifications.

The Kadant Johnson Warranty

Kadant Johnson products are built to a high standard of quality. Performance is what you desire: that is what we provide. Kadant Johnson products are warranted against defects in materials and workmanship for a period of one year after date of shipment. It is expressly understood and agreed that the limit of Kadant Johnson's liability shall, at Kadant Johnson's sole option, be the repair or resupply of a like quantity of non-defective product.



www.kadantjohnson.com