

# Disassembly and Repair Instructions of Type RX Joints (2" – 3")

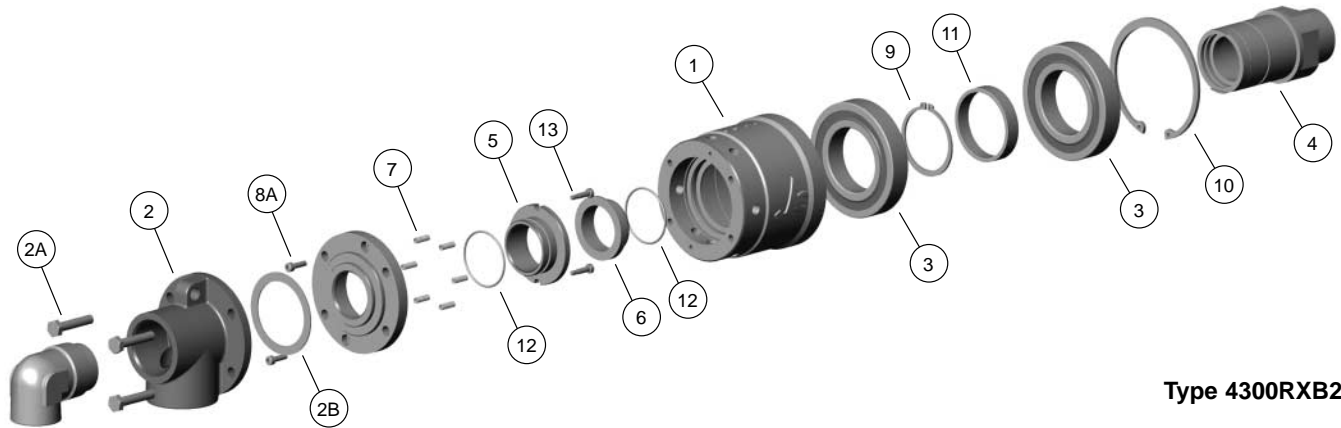

Type 4300RXB2

**NOTE:** Please follow your company's safety procedures whenever working on Kadant Johnson rotary joints and read all of the instructions completely before proceeding.

Please refer to the assembly drawings supplied with your Kadant Johnson rotary joint for part identification. If you have any questions, please contact your Kadant Johnson Representative or Kadant Johnson.

Release residual pressure in the system. Close the inlet and outlet valve. Allow the joint to cool sufficiently and then disconnect the inlet and outlet piping from the joint.

#### SEAL REPAIR KITS:

2" Size	RK-4200RX-SR	-1, -2, or -3
2.5" Size	RK-4250RX-SR	-1, -2, or -3
3" Size	RK-4300RX-SR	-1, -2, or -3

#### CONSISTING OF:

		RK-4200RX-SR	RK-4250RX	RK-4300RX
Description	Item #	Qty	Qty	Qty
Gasket	2B	1	1	1
Seal Ring	5	1	1	1
Counterseat	6	1	1	1
Spring	7	6	8	10
O-Ring	12	2	2	2
*Lip Seal	14	1	1	1
O-Ring Lube	-	1	1	1

\*Lip seal only supplied in -1, -2, or -3 versions.

**NOTE:** Do not use anti-seize or petroleum-based products on o-rings. Only lubricate the o-rings with the lubricant supplied with the Kadant Johnson repair kit. Applications up to 350F, use Parker silicone o-ring lubricant. Applications over 350F, use the same grease that is used in the bearings of the joint (Krytox GPL 227). Use latex gloves when handling o-ring lubricant.

#### CARBON SEAL REPLACEMENT – ON OR OFF MACHINE

##### STEP 1.

Loosen and remove hex head cap screws (2A) and set aside. Remove head (2).

##### STEP 2.

Loosen and remove socket head cap screws item (8A) and assembly plate (8). Set aside socket head cap screws. The seal ring and counterseat will now be exposed.

##### STEP 3.

Loosen and remove shoulder screws (13) from the assembly plate and set aside. Take care in this, as it will release the seal ring (5) from the assembly plate. Remove and discard seal ring, springs (7) and o-ring (12).

##### STEP 4.

Remove the counterseat insert (6), and o-ring (12) from nipple (4) and discard.

##### STEP 5.

Inspect bushing in elbow if equipped (Dual Flow). Replace elbow and bushing if worn. Inspect bearings. If they need replacing, follow "Bearing Replacement" instructions.

##### STEP 6.

Carefully clean the end of the nipple and the inside of the assembly plate where the seal ring sits. Do not scratch surfaces. Also clean gasket material from head and the assembly plate. This can be done using a light wire brush or flat scraper.

##### STEP 7.

Apply a small amount of o-ring lube to both sides of new o-ring for the seal ring and fit it over the end of the new seal ring (5) and into o-ring groove. Insert new springs (7) into holes in assembly plate (31).

##### STEP 8.

Place a clean soft cloth over the sealing face of the seal ring (5). Align the notches in the seal ring with the tapped holes for the shoulder screws in the assembly plate and gently press the seal ring into the bore of assembly plate. While holding the seal ring into the assembly plate, reinstall the shoulder screws (13) to hold seal ring in place. The springs should push the seal ring against the heads of the shoulder screw. If seal does not rest against the shoulder screws, disassemble and inspect the o-ring for damage or other obstructions. Set the assembly plate aside.

##### STEP 9.

Apply a small amount of o-ring lube to both sides of new o-ring for the counterseat and fit it into the gland in the end of the nipple. Aligning the flats on the OD of the new counter seat (6) with the raised ends of the nipple, gently press the counterseat into the nipple. To ensure the o-ring stays in the gland while the counterseat is installed, the o-ring can be stretched slightly.

##### STEP 10.

Ensure seal faces are clean. O-ring lube should be cleaned from counterseat and seal ring with acetone and a clean lint-free cloth.

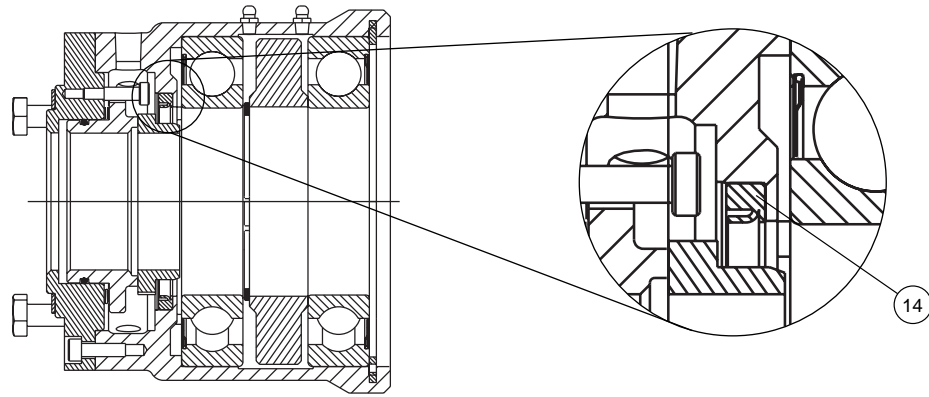

Figure 1

**STEP 11.**

While holding the assembly plate in place, reinstall and tighten socket head cap screws (8A).

**STEP 12.**

Place the new gasket onto the assembly plate. Reinstall head (2) and tighten hex head cap screws (2A) to the proper torque using a star pattern. Please refer to Kadant Johnson drawing number A37640 for torque specifications.

**BEARING REPLACEMENT**

**BEARING REPAIR KITS:**

2" Size	RK-4200RX-BK	-1, -2, or -3
2.5" Size	RK-4250RX-BK	-1, -2, or -3
3" Size	RK-4300RX-BK	-1, -2, or -3

**Note:** In addition to new bearings, the bearing repair kit also includes the seal repair kit components.

If bearing replacement is required, follow steps listed below for replacement of the ball bearings.

To begin follow steps 1 through 4 under "Carbon Seal Replacement."

**STEP 1.**

Remove body (1) and bearing assembly (3) from roll. Remove retaining ring (10) from body and keep for use again.

**STEP 2.**

The joint bearings are a slip fit into the body of the joint and onto the OD of the nipple. With the retaining ring (10) removed, the nipple (4) with bearings (3) should slide out of the body. If the nipple and bearings do not slide out freely, light pressure can be applied to the end of the nipple while holding the body in a press. In some cases the outward bearing may remain in the body with the nipple removed and can be dislodged by tapping it out with a rod through the tapped holes on the opposite end of the body.

**STEP 3.**

**If equipped,** tap out the lip seal (14) from the body using a screwdriver. Clean and dry the inside of the body. See Figure 1.

**STEP 3A.**

Press new lip seal into the body. Use a piece of pipe or tubing to press in the lip seal that will apply pressure only to the metal OD of the seal. See Figure 1.

**STEP 4.**

With outward bearing (3) removed. Remove retaining ring (9) from nipple and set aside for use later. Slide the bearing spacer (11) and inward bearing (3) off the nipple. Clean and dry the nipple and bearing spacer for reuse.

**STEP 5.**

In the standard bearing kit the bearings are pre-greased. For the -1, -2, and -3 versions grease will need to be added; fill the cavity between each ball with the appropriate grease (SHC PM temp. up to 300F and Krytox GPL 227 temp. above 300F).

**STEP 6.**

Slide the first new bearing (3) onto the nipple until it is seated against the shoulder of the nipple. For bearings with one shield, the first bearing should be installed with the shield down. If the joint has a flanged nipple, the retaining ring (10) should be placed over the end of the nipple before installing the bearings.

**STEP 7.**

Slide the bearing spacer onto the nipple to rest against the first bearing.

**STEP 8.**

Install the retaining ring (9) onto the nipple.

**STEP 9.**

Slide the second new bearing (3) onto the nipple to rest against the retaining ring (9). If a bearing with just one shield is used (-1, -2, or -3 version), the open side should be facing down. When the assembly is complete, the open sides of the single shielded bearing should be resting against the bearing spacer and the snap ring.

**STEP 10.**

Place body over bearing/nipple assembly and slide into place. If the body does not slide freely over the bearings, remove and inspect for burrs, etc. Minimal force should be applied to the body to slide it over the bearings, to prevent any damage to the bearings.

**STEP 11.**

While holding assemblies together, turn over onto a flat surface and install retaining ring (10).

**STEP 12.**

Add grease through the grease fitting. Contact Kadant Johnson for grease specifications and quantity.

**STEP 13.**

Follow steps 6 through 12 under "Carbon Seal Replacement" to complete repairs.

Reinstall the joint onto the roll. The Kadant Johnson joint is now ready to be placed back in service.

Please refer to Kadant Johnson drawing number A37640 for torque specifications.

The Kadant Johnson Warranty

Kadant Johnson products are built to a high standard of quality. Performance is what you desire: that is what we provide. Kadant Johnson products are warranted against defects in materials and workmanship for a period of one year after date of shipment. It is expressly understood and agreed that the limit of Kadant Johnson's liability shall, at Kadant Johnson's sole option, be the repair or resupply of a like quantity of non-defective product.



www.kadantjohnson.com