

## Disassembly and Repair of Type LJ-PT Joints

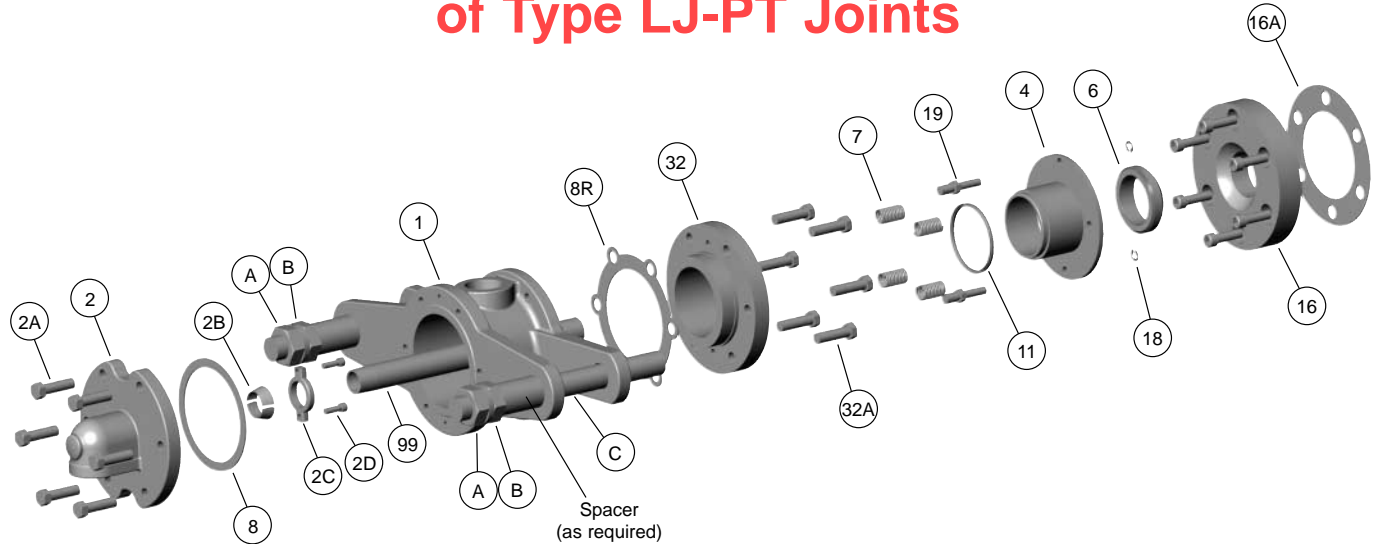

### Type LJ-PT

#### REPAIR KITS ARE AVAILABLE CONSISTING OF:

Item #	Qty	Description
6	1	Carbon Seal
7	*	Spring
8	1	Gasket
18	*	Retainer Ring
11	1	Energized Seal or (2) O-rings
CSL500-14	1	Silicone Lube

\*Quantity varies with joint sizes.

**NOTE:** Please follow your company's safety procedures whenever working on Kadant Johnson rotary joints and read all of the instructions completely before proceeding.

Please refer to the assembly drawings supplied with your Kadant Johnson rotary joint for part identification. If you have any questions, please contact your Kadant Johnson Representative or Kadant Johnson.

#### REMOVAL:

##### STEP 1.

Close the inlet and outlet valve. Allow the joint to cool sufficiently.

##### STEP 2.

Release residual pressure in the system and disconnect the inlet and outlet piping from the joint.

##### STEP 3.

Remove head bolts (2A) and remove the head (2) from the body (1). If the head is equipped with a pressure plate (2C) and split rings (2B), loosen the screws (2D) before attempting to remove the horizontal pipe (99).

##### STEP 4.

Loosen and unscrew jam nuts (A & B) on each support rod (C).

##### STEP 5.

Slide the joint away from the journal flange. Be prepared to capture the carbon seal ring (6) as it falls free.

##### STEP 6.

Remove the end cap assembly (32) from the body (1) by removing the hex head cap screws (32A).

##### STEP 7.

Remove the nipple (4) from the end cap (32) by placing the assembly into a press with the nipple's sealing (flat) surface facing up. Protect the nipple's sealing surface from damage. Push the nipple into the end cap far enough to remove the retainer rings (18) from the spring guide pin (19). Release the press and remove the nipple.

**Note:** Some applications use an o-ring in place of the energized seal (11). The o-ring/energized seal may be located in the nipple (4) or the end cap (32) depending on joint size. Please replace this component and clean the area as required.

##### STEP 8.

If the energized seal or o-ring (11) is located in the end cap (32), remove it and discard. Clean and inspect the energized seal/o-ring gland. Clean and inspect the bore where the nipple slides through the end cap. Clean and inspect gasket surfaces. Replace the end cap if any area is damaged.

##### STEP 9.

If the energized seal or o-ring (11) is located in the nipple (4), remove it and discard. Clean and inspect the energized seal/o-ring gland. Inspect the flat seal ring surface of the nipple for wear. Clean and inspect the end of the nipple that passes through the end cap. If any area is damaged, replace the nipple.

**STEP 10.**

Using a silicone lubricant, lubricate and install a new energized seal or o-ring in its proper location, either the nipple or end cap.

**STEP 11.**

Replace the springs (7) on the end cap.

**STEP 12.**

Using a press, push the nipple into the bore of the end cap while aligning it with the spring guide pins (19). Once the nipple flange passes by the spring guide pins, install the retainer rings (18). Release the press.

**STEP 13.**

Clean the gasket surfaces on the body (1). Place a new gasket (8R) on the end cap side of the body. Attach the end cap assembly (4, 32, 11, 7 & 18) to the body using hex head cap screws (32A). Tighten the bolts using a star pattern and the proper torque. See Kadant Johnson Drawing Number A37640 for torque specifications.

**STEP 14.**

Inspect wear plate (16) for wear or damage. Replace the wear plate if necessary, using a new gasket (16A).

**REINSTALLATION:****STEP 15.**

Thread the horizontal pipe into the head (2). If equipped, tighten the pressure plate screws (20). Install a new head gasket (8) and secure the head to the body using head bolts (2A). Tighten

the head bolts using a star pattern and the proper torque. See Kadant Johnson Drawing Number A37640 for torque specifications.

**STEP 16.**

Using a new carbon seal (6), slide the rotary joint over the support rods. Using adjusting nuts B, move the joint housing in until setup dimension (X) is achieved. The dimension varies with joint size. Refer to the Kadant Johnson assembly drawing for your particular rotary joint. Once in position, thread lock nut A onto the support rod and tighten against nut B.

**STEP 17.**

Attach the inlet and outlet piping, open the valves, and the joint is ready for service.

Periodically monitor the carbon seal wear by observing the distance between the retainer rings on the spring guide pins and the nipple flange that they pass through. When the seal is completely worn, the nipple flange will rest against the retainer rings and the joint will leak, requiring repairs. This feature prevents metal to metal contact between the nipple and the wear plate.

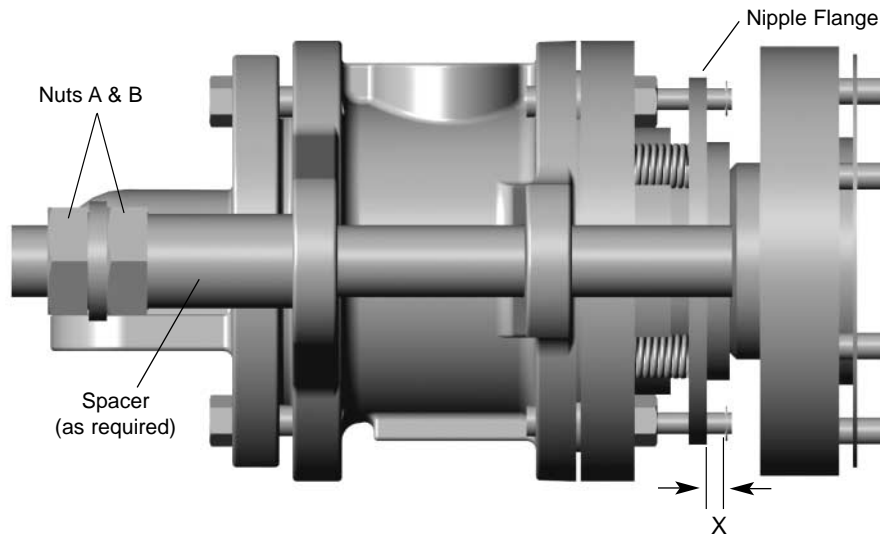
**The Kadant Johnson Warranty**

Kadant Johnson products are built to a high standard of quality. Performance is what you desire: that is what we provide. Kadant Johnson products are warranted against defects in materials and workmanship for a period of one year after date of shipment. It is expressly understood and agreed that the limit of Kadant Johnson's liability shall, at Kadant Johnson's sole option, be the repair or resupply of a like quantity of non-defective product.



[www.kadantjohnson.com](http://www.kadantjohnson.com)