

# Installation Instructions for Turbulator® Bars

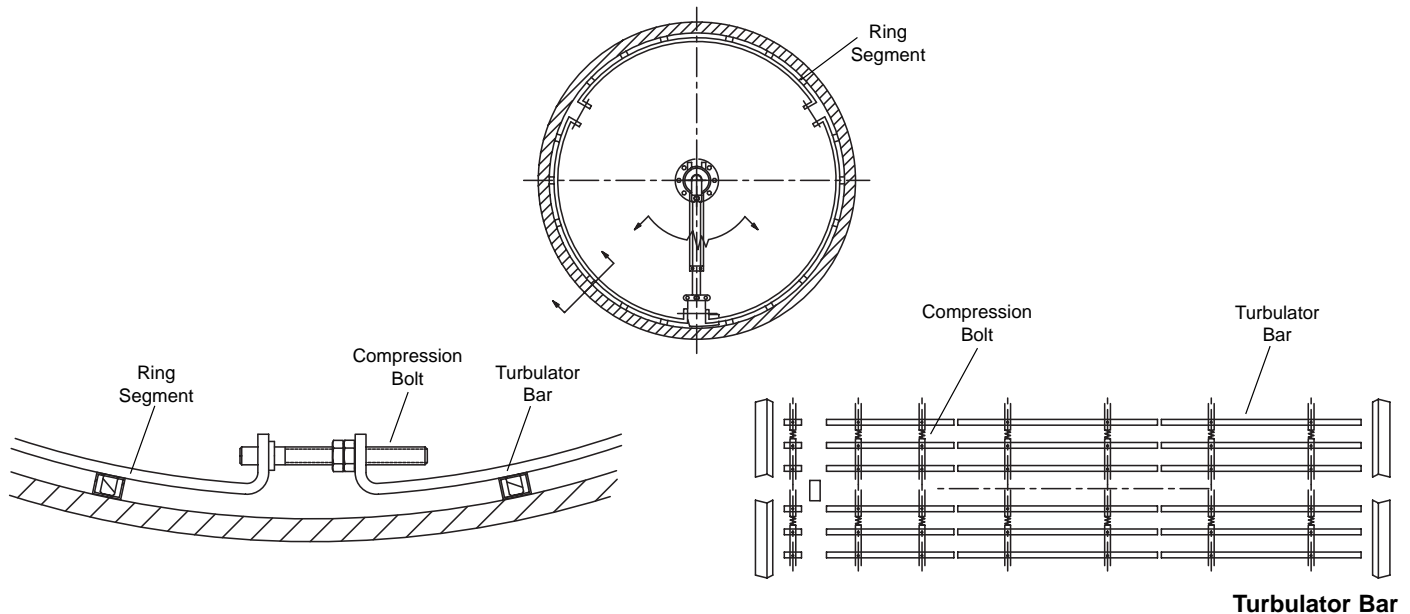

**NOTE:** Please follow your company's safety procedures whenever working on Kadant Johnson Turbulator bars and read all of the instructions completely before proceeding.

Please refer to the assembly drawings supplied with your Kadant Johnson Turbulator bar for part identification. If you have any questions, please contact your Kadant Johnson Representative or Kadant Johnson.

## STEP 1.

Kadant Johnson assembly drawing will show the layout for the Turbulator bar installation. This drawing will have a number similar to TXA-xxx-xxx.

## STEP 2.

Stage the tools required for the bar installation. Tools include, per installation team:

- Pneumatic or manual 3/8" drive ratchet
- 10 mm (3/8") short Allen wrench socket
- Two 24 mm (15/16") open end wrenches
- Tape measure
- Two magnets available from Kadant Johnson
- Torque wrench

## STEP 3.

Select a staging area for installation of the Turbulator bars. Unpack the Turbulator bars. Check the Kadant Johnson assembly drawing to be sure that all parts are in the staging area. There should be a series of Turbulator bars (tube bars, each with two holes in them), a series of ring segments (three segments per ring, each with locking pins installed), and a set of compression bolts (three bolts for each ring, each bolt with two nuts).

## STEP 4.

Check the flat portion width of the dryer shell, from the base of the taper of the shell flange on one side to the base of the taper of the shell flange on the other side. Check to be sure that this corresponds to the dimension shown on the Kadant Johnson drawing. Consult factory if dimensions are different.

## STEP 5.

It is best to have two people inside the dryer for the installation, with an additional person outside the dryer, to pass the equipment into the dryer and to act as a safety spotter. Begin the installation on the back (drive) side of the machine. If a new syphon is being installed, install the syphon first. A typical dryer will have a series of long bars and a single trim segment. Check the drawing for proper layout.

## STEP 6.

Position the first set of bars starting 25 mm to 40 mm (1.0" to 1.5") from the end of the dryer shell flange taper, as indicated on the assembly drawing. If there is a stationary syphon, position the first set of bars 25 mm to 40 mm (1.0" to 1.5") from the edge of the syphon shoe, as indicated on the assembly drawing. Do so by marking the dryer shell with chalk in several circumferential locations, to assist in aligning the first set of bars.

## STEP 7.

Begin by placing two bars on the bottom of the dryer shell near the six o'clock position, parallel with the length of the dryer. Make sure the holes in the bar are facing up and space the bars about 7" apart. Put the pin, nearest the bent tab on the ring segment, into the hole on top of the bar nearest the head of the dryer. Allow the ring segment to rest against the dryer shell. Repeat this for the other bar. One ring segment should now be at the six o'clock to the two o'clock position and the other ring

segment should be from the six o'clock to the ten o'clock position, both resting on the dryer shell. Place the head of the compression bolt through the hole in the bent tab on the end of the ring segment and the threaded end through the hole in the bent tab on the end of the adjacent ring segment, where the two segments come together at the bottom of the dryer. Repeat this setup at the other end of the bar.

#### STEP 8.

Begin by slightly lifting the ring segment and sliding a bar underneath it. Engage the bar into the set of pins on the ring segment that is adjacent to the bar that was installed in Step 10. Install the remaining bars by sliding them, one at a time, down the dryer shell, behind the ring segments. Lift the ring segments away from the dryer to get clearance for the bar. Once the bar is in position, align the holes in the bar to the pins on the ring segment.

Alternate bar placement from one side to the other side during this step, this will prevent the assembly from becoming too heavy on one side and sliding down the dryer shell.

**Helpful Hint:** When placing bars under the lower two segments, place your foot on top of the ring segment, near the five and seven o'clock positions. This helps to hold the bars down against the dryer and keep them from sliding off the pins in the ring segments.

#### STEP 9.

As the bars are positioned, fully engage the pins by progressively moving the ring segments toward the dryer shell. Once all of the bars are in position, place a magnet over a ring segment, one magnet on each side of the Turbulator bars to help steady the assembly. See Figure 1. Magnets are available from Kadant Johnson.

#### STEP 10.

After the bars are connected to the pins in the lower two ring segments, set the top ring segment on top of the two lower segments, with the compression bolts between the tabs. This top segment will be hanging below the surface of the dryer shell until the compression bolts are tightened (see Step 12).

**NOTE:** The ring segments and the compression bolts are symmetrical. They can be installed in either direction. Typically, the heads on the ends of all of the compression bolts are positioned in the same direction, but this is not necessary.

#### STEP 11.

Slide the Turbulator bars between the top ring segment and the dryer shell, one at a time, until all of the bars are in place. Set each bar on top of the ring segments with the pins going into the holes in the bars.

#### STEP 12.

When the bars are in place, tighten the three compression bolts by turning the nuts in a counter-clockwise direction. Allow for equal spacing in each of the gaps between bent tabs. Align the bars to the hatch marks that were made in Step 6.

Either a pneumatic air wrench or a manual ratchet wrench can be used for tightening the nuts on the compression bolts. Note that the ratchet needs to be set for counter-clockwise rotation to tighten the bolts against the ring segments.

#### STEP 13.

After all of the compression bolts are in position, tighten them to 27 N-m (20 ft-lbs), using a torque wrench.

#### STEP 14.

Tighten the jam nuts for each of the compression bolts. Use a pair of open-end wrenches for this and apply approximately 100 N-m (75 ft-lbs) of torque to seat the two nuts against each other. Remove any magnets used in Step 9.

#### STEP 15.

Align the next segment of bars with the bars previously installed. The gap between the ends of the bars should be 5 mm to 15 mm (0.2" to 0.6"). When the last segment is installed, the gap to the base of the taper of the dryer flange should be about 25 mm to 40 mm (1.0" to 1.5").

*Dimensions are for reference only and subject to change. Certified drawings are available on request.*

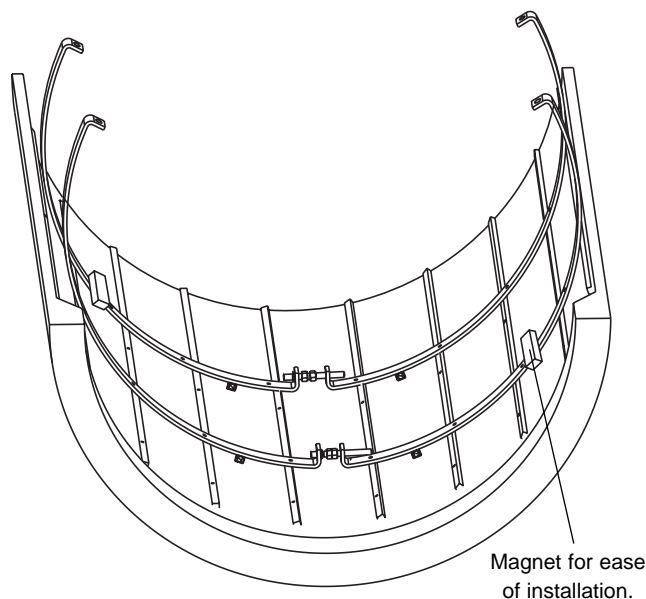

Figure 1.

#### The Kadant Johnson Warranty

Kadant Johnson products are built to a high standard of quality. Performance is what you desire: that is what we provide. Kadant Johnson products are warranted against defects in materials and workmanship for a period of one year after date of shipment. It is expressly understood and agreed that the limit of Kadant Johnson's liability shall, at Kadant Johnson's sole option, be the repair or resupply of a like quantity of non-defective product.

**KADANT**  
JOHNSON

[www.kadantjohnson.com](http://www.kadantjohnson.com)