

# Installation Instructions for Split Wedge Syphon Support

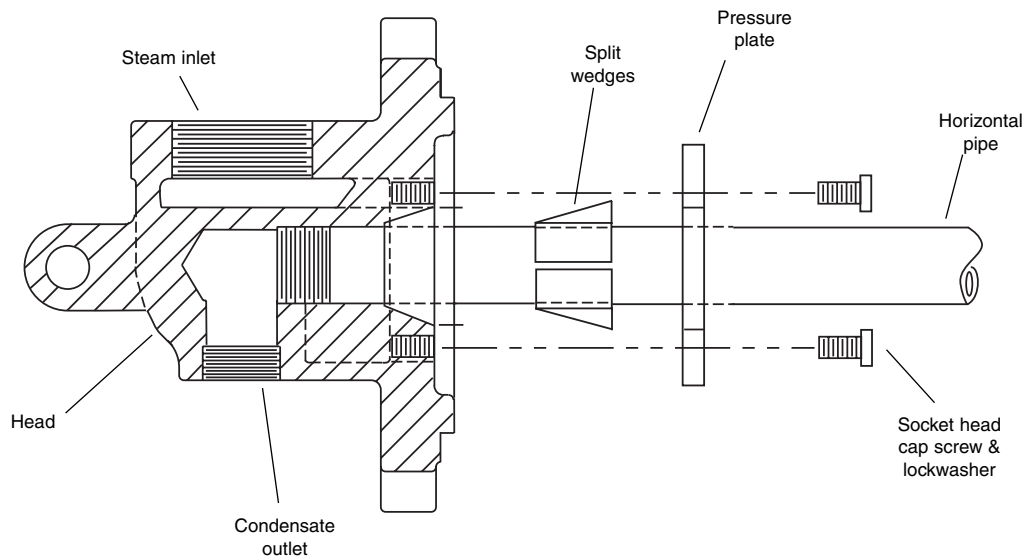

Please follow your company's safety procedures whenever working on Kadant Johnson rotary joints and read all of the instructions completely before proceeding.

Please refer to the assembly drawings supplied with your Kadant Johnson rotary joint for part identification. If you have further questions, please contact your Representative or Kadant Johnson.

## STEP 1

Unbolt head and remove from rotary joint. Insert horizontal pipe into cylinder. Install pressure plate over horizontal pipe.

## STEP 2

Slide horizontal pipe with pressure plate onto joint. Tighten horizontal pipe into head.

## STEP 3

Position syphon pipe such that the pick-up location (syphon opening) points downward at the 6 o'clock position.

## STEP 4

Slide split wedges into the head.

## STEP 5

Tighten pressure plate over split wedges.

## STEP 6

Attach head to rotary joint.

### The Kadant Johnson Warranty

Kadant Johnson products are built to a high standard of quality. Performance is what you desire: that is what we provide. Kadant Johnson products are warranted against defects in materials and workmanship for a period of one year after date of shipment. It is expressly understood and agreed that the limit of Kadant Johnson's liability shall, at Kadant Johnson's sole option, be the repair or resupply of a like quantity of non-defective product.

**KADANT**  
AN ACCENT ON INNOVATION  
www.kadant.com

# Installation Instructions for Split Wedge Syphon Support

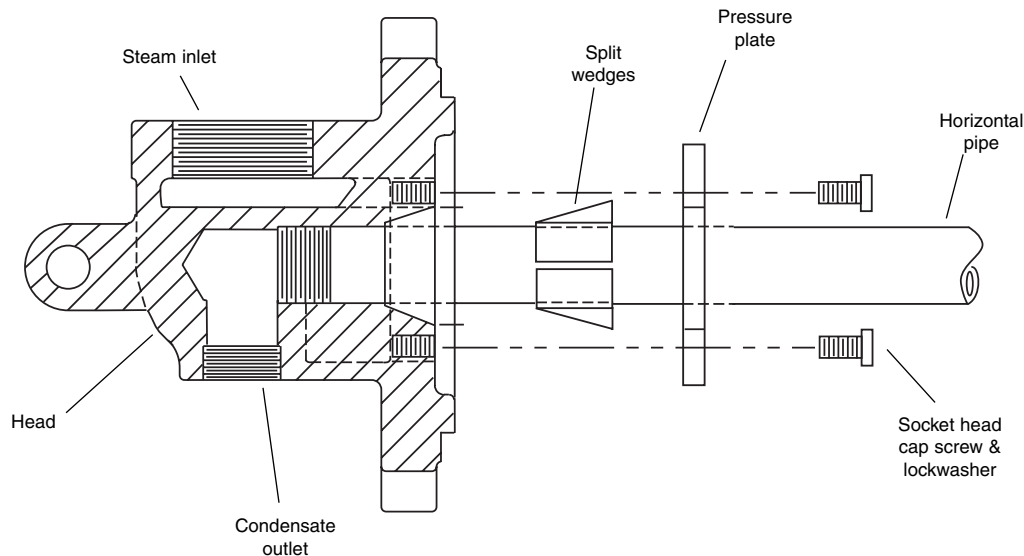

Please follow your company's safety procedures whenever working on Kadant Johnson rotary joints and read all of the instructions completely before proceeding.

Please refer to the assembly drawings supplied with your Kadant Johnson rotary joint for part identification. If you have further questions, please contact your Representative or Kadant Johnson.

## STEP 1

Unbolt head and remove from rotary joint. Insert horizontal pipe into cylinder. Install pressure plate over horizontal pipe.

## STEP 2

Slide horizontal pipe with pressure plate onto joint. Tighten horizontal pipe into head.

## STEP 3

Position syphon pipe such that the pick-up location (syphon opening) points downward at the 6 o'clock position.

## STEP 4

Slide split wedges into the head.

## STEP 5

Tighten pressure plate over split wedges.

## STEP 6

Attach head to rotary joint.

### The Kadant Johnson Warranty

Kadant Johnson products are built to a high standard of quality. Performance is what you desire: that is what we provide. Kadant Johnson products are warranted against defects in materials and workmanship for a period of one year after date of shipment. It is expressly understood and agreed that the limit of Kadant Johnson's liability shall, at Kadant Johnson's sole option, be the repair or resupply of a like quantity of non-defective product.

**KADANT**  
AN ACCENT ON INNOVATION  
www.kadant.com