

# Installation Instructions for Type Bearing Cover Inserted (BCI) C-Cast Joints

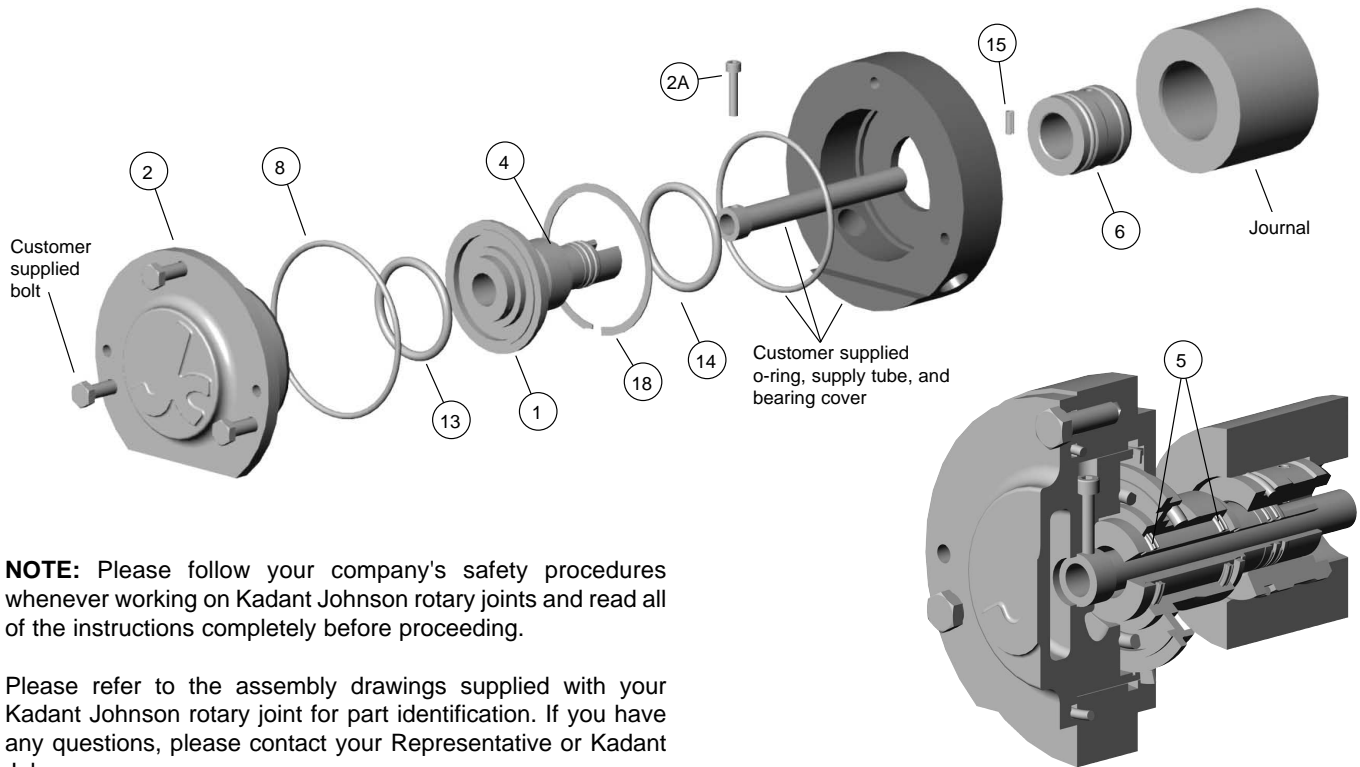

**NOTE:** Please follow your company's safety procedures whenever working on Kadant Johnson rotary joints and read all of the instructions completely before proceeding.

Please refer to the assembly drawings supplied with your Kadant Johnson rotary joint for part identification. If you have any questions, please contact your Representative or Kadant Johnson.

The joint is assembled and tested prior to leaving the factory and is meant to be installed as an assembly. Only remove the head casting (2) if you find it difficult to align the nipple and supply tube. To remove the head, remove the retaining ring (18). Be careful that the o-ring (8) does not fall out of position.

**Note:** For dual flow joints, slide the supply pipe into the nipple (4) and engage it into the recess in the head (2). Secure into position using cap screws (2A). The inlet and outlet connections are aligned with a flat on the head. Supply flow must enter the roll through the center pipe.

**STEP 1.**

Clean the I.D. of the roll journal and bearing cover. This is where the o-ring seals once the insert and joint are installed.

**STEP 2.**

Press the insert (6) into the journal carefully and straight so as not to damage the parts.

**STEP 3.**

Coat o-ring (8) with the silicone lubricant supplied by Kadant Johnson.

**Step 4.**

Insert the joint assembly (1 and 4) through the bearing cover so that the nipple slot is aligned with the pin (15) in the insert (6). If this is a dual flow joint, be sure the center pipe engages in the roll's recess.

**Step 5.**

If head (2) was removed, you can now slide the head into the bearing cover, being careful not to damage the o-ring in the head. The retaining ring (18) is not required if the head is installed separately.

**Step 6.**

Lubricate the fasteners and attach the head flange (2) to the bearing cover.

**STEP 7.**

Under no circumstances should the nipple (4) be removed from body (1) as it will damage the Quad Seals\* (5). If the nipple (4) is removed, the Quad Seals (5) will need to be replaced.

Repair kits are available from Kadant Johnson. If you should need further assistance, contact Kadant Johnson.

\*Registered trademark of Minnesota Rubber Co.

The Kadant Johnson Warranty

Kadant Johnson products are built to a high standard of quality. Performance is what you desire: that is what we provide. Kadant Johnson products are warranted against defects in materials and workmanship for a period of one year after date of shipment. It is expressly understood and agreed that the limit of Kadant Johnson's liability shall, at Kadant Johnson's sole option, be the repair or resupply of a like quantity of non-defective product.

