

# Installation Instructions for Type S Joints

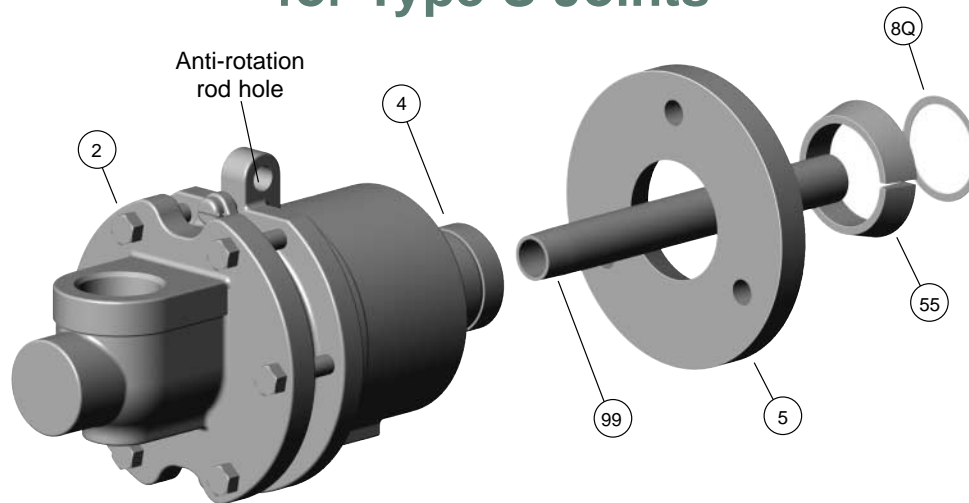

Type SBP

## For stationary syphon, distribution pipe and through-flow applications

**NOTE:** Please follow your company's safety procedures whenever working on Kadant Johnson rotary joints and read all of the instructions completely before proceeding.

Please refer to the assembly drawings supplied with your Kadant Johnson rotary joint for part identification. If you have any further questions, please contact your Representative or Kadant Johnson.

### STEP 1.

Check to make sure that all debris has been removed from the piping, roll, dryer, or cylinder before installing joint. This will help reduce carbon seal ring scoring and damage to internal joint parts which could cause unnecessary downtime and maintenance.

### STEP 2.

Insert the horizontal pipe into the nipple (4) and thread the horizontal pipe (99) into the rotary joint head (2).

**IMPORTANT:** THE HORIZONTAL PIPE MUST BE STRAIGHT AND TRUE. THIS WILL PREVENT EXCESSIVE PIPE WEAR AND PIPE BREAKAGE.

### STEP 3.

For quick release nipple (4) connections to your journal; place a new copper gasket (8Q) into the journal flange. Slide the quick release nipple flange (5) over the rotary joint nipple (4) with its taper facing outward. Place two split taper wedges (55) into recess of the nipple tube and then slide the quick release flange over them. Lift the joint up and slide the nipple (4) into the journal flange recess and secure to the studs with nuts provided, tightening evenly. Note that the quick release nipple flange (5) will not seat tightly against the face of the journal flange. When tight, there should be 1/8" – 3/16" space between the two flanges.

If the rotary joint has a threaded nipple connection for attachment to your roll, simply thread it into the journal.

### STEP 4.

Connect the rotary joint to the piping using flex hose. For the best results use two flex hoses on each of the inlet and outlet connections. See Figure 1. This piping configuration will ensure that the rotary joint has the ability to move as seal ring wear occurs. Avoid attaching hard piping directly to the rotary joint, this will increase the weight supported by the joint. Any additional weight will cause premature rotary joint failure. Make sure the piping is properly supported beyond the flex hose. See Table 1 for recommend flex hose length.

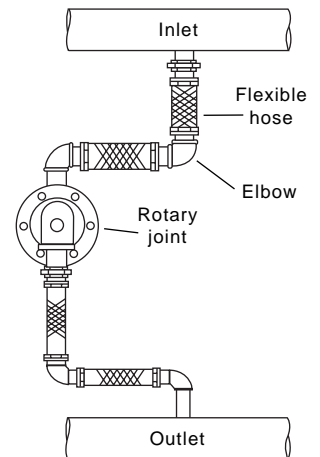

Figure 1

### STEP 5.

Install anti-rotation rod through the anti-rotation hole in each joint using Schedule 80 pipe. No more than two joints should be joined with one rod. Secure the rod by drilling a hole for a cotter pin through the rod on the outer most side of each joint lug. The rod will absorb the torque generated by the joint, and prevent premature hose failure by reducing stresses.

This completes the installation. The joint is now ready for service.

**NEVER APPLY OIL OR GREASE TO KADANT JOHNSON JOINTS. THE SATURATED STEAM, CONDENSATE OR LIQUID PASSING THROUGH IS THE ONLY LUBRICATION REQUIRED FOR THE CARBON-GRAPHITE PARTS.**

**MINIMIZE RUNNING KADANT JOHNSON JOINTS DRY. EXCESSIVE CARBON SEAL WEAR MAY OCCUR.**

**CAUTION**

Check the rotary joint regularly for carbon seal ring wear. Should the carbon seal ring wear away completely, the metal nipple can wear into the joint body, and eventually through it. This will result in a leak, creating a hazardous condition, and will require replacement of the entire joint instead of just the seal ring.

**TABLE 1**

Joint Size	Seal Wear
3/4"	1/4"
1"	3/8"
1-1/4"	3/8"
1-1/2"	5/16"
2"	3/8"
2-1/2"	3/8"
3"	7/16"
3-1/2"	7/16"
4"	9/16"

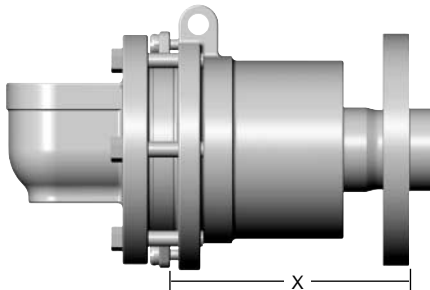

**PROCEDURE FOR DETERMINING CARBON SEAL RING WEAR**

**STEP 1.**

Measure the distance for dimension (X) as shown above when the joint is new.

**STEP 2.**

Reference Table 1 for your particular joint size. Remember that as the carbon seal ring begins to wear, the joint moves (due to pressure) away from the cylinder journal end.

**STEP 3.**

Add dimension "X" to the number you found in Table 1 (see Step 2). As the seal wears dimension "X" will increase.

**STEP 4.**

Refer to Table 1. When "X" has increased the thickness of seal wear indicated you should replace the seal ring.

**RECOMMENDED MINIMUM HOSE LENGTHS**

Hose Size	Minimum Length
1/4"	8"
3/8"	10"
1/2"	10"
3/4"	12"
1"	15"
1-1/4"	18"
1-1/2"	18"
2"	21"
2-1/2"	24"
3"	27"

**LUGS FOR ANTI-ROTATION RODS**

The use of an anti-rotation rod is a common method with self-supporting joints, especially with higher speeds and pressures. It is real assurance that the joint will not turn should it bind or seize for any reason. Furthermore, the anti-rotation rod greatly increases the life of the connecting hose by relieving it of all strains and tension. All Type S Kadant Johnson joints, with the exception of the Series 4000 Type SA, are provided with lugs for anti-rotation rods. Sizes smaller than 1" have lugs on head only. Sizes 1" and larger have lugs on both head and body.

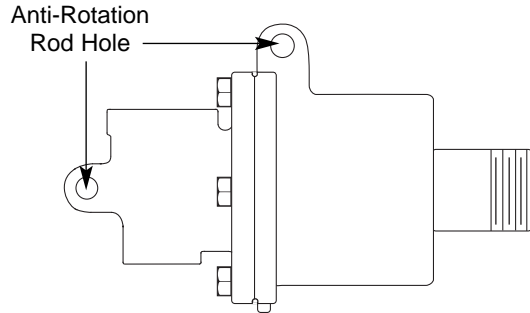

The 3000 Series Joints (1" and larger) have lugs on both head and body. Joints smaller than 1" have lugs on head only.

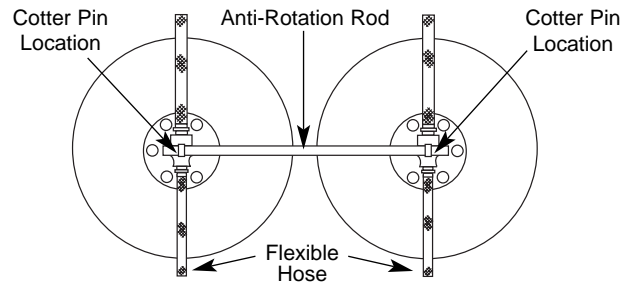

Horizontal installation of rod in head lugs.

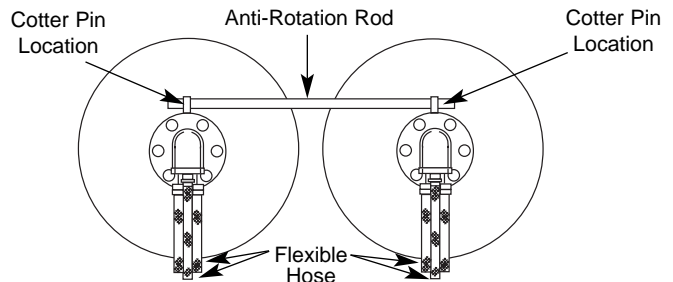

Horizontal installation of rod in body lugs.

**RECOMMENDED SIZES FOR ANTI-ROTATION RODS**

Joint Size	Joint Number	Schedule 80 Pipe Size
3/4"	2200	1/8"
1"	2300	1/8"
1-1/4"	2400	1/4"
1-1/2"	2500	1/4"
2"	2550	1/4"
2-1/2"	2600	3/8"
3"	2700	1/2"

Dimensions are for reference only and subject to change. Certified drawings are available on request.

The Kadant Johnson Warranty

Kadant Johnson products are built to a high standard of quality. Performance is what you desire: that is what we provide. Kadant Johnson products are warranted against defects in materials and workmanship for a period of one year after date of shipment. It is expressly understood and agreed that the limit of Kadant Johnson's liability shall, at Kadant Johnson's sole option, be the repair or resupply of a like quantity of non-defective product.



www.kadantjohnson.com